

FEATURES

- Input for RTD type Pt100
- Unit of measure configurable in °C or °F
- Zero and Span values configurable by DIP-switches
- Linearised voltage or current output
- Good accuracy and performance stability
- EMC compliant – CE mark
- DIN rail mounting in compliance with EN-50022 and EN-50035



GENERAL DESCRIPTION

The converter DAT 2165 is designed to provide on its output a linearised voltage or current signal proportional with the temperature characteristic of the Pt100 sensor connected on its input.

It is possible to connect on the input both 3 wires and 2 wires Pt100.

The user can program the input and output ranges by the proper DIP-switches available after opening the suitable door located on the side of device (see "Input range table" and "Output range table" sections).

The regulation of Zero and Span values is made by the ZERO and SPAN potentiometers located on the top of device.

It has been made in compliance with the EEC/336/89 standard on the Electromagnetic Compatibility.

It is housed in a plastic enclosure of 12.5 mm thickness suitable for DIN rail mounting in according to EN-50022 and EN-50035 standards .

OPERATIVE INSTRUCTIONS

The converter DAT 2165 must be powered by a direct voltage included in the 18 V to 30 V range. The power supply must be applied between the terminals R (+Vdc) and P (GND), or alternatively between the terminals Q (+Vdc) and O (GND).

The current or voltage output signal is measurable between the terminals N (OUT V/I) and P (GND), or alternatively between the terminals M (OUT V/I) and O (GND).

The input connections must be made as shown in the section "Input connections".

The 3 wires Pt100 must be connected between the terminals G and I, while the third wire must be connected to the terminal E or alternatively connect the sensor between the terminals H and L while the third wire must be connected to the terminal F .

The 2 wires Pt100 must be connected between the terminals G and I, making a short circuit between the terminals G and E or alternatively connect the sensor between the terminals H and L making a short circuit between the terminals H and F .

The configuration of input and output ranges values is made by DIP-switches (refer to the section "Input range table" and "Output range table").

After the converter configuration, it is necessary to calibrate it using the ZERO and SPAN regulations; this operation is illustrated in the section "DAT 2165: Configuration and calibration".

To install the device refer to the section "Installation instructions".

TECHNICAL SPECIFICATIONS (Typical @ 25 °C and in nominal conditions)

Input	
Sensor type	2 or 3 wire Pt100 in according to IEC60751 standard
Minimum input Span	50 °C (122 °F)
Zero programmability	From -50 °C (-58 °F) up to + 50 °C (122 °F)
Span programmability	From 50 °C (122 °F) up to 650 °C (1202 °F)
Sensor excitation current	1 mA typ.
Line resistance influence	0.05 % of f.s./ohm (100 ohm max. balanced per wire)
Output	
Signal type	Configurable: 4 ÷ 20 mA, 0 ÷ 20 mA, 0÷10 V
Burnout condition	Positive out of scale (> 20 mA or > 10 V)
Maximum output signal	32 mA or 18 Vdc
Load resistance (Rload)	Current output: < /= 500 Ω Voltage output: > /= 5 KΩ
Response time (from 10 to 90 % of f.s.)	300 ms
Warm-up time	3 minutes
Performances	
Calibration error	± 0.1 % of f.s.
Linearity error (*)	± 0.15 % of f.s.
Thermal drift	0.020 % of f.s./°C
Power supply voltage (**)	18 ÷ 30 Vdc
Current consumption	Current output: 40 mA max. Voltage output: 10 mA max.
Electromagnetic Compatibility (EMC) (for industrial environments)	Immunity: EN 61000-6-2; Emission : EN 61000-6-4.
Operating temperature	-20 to 70 °C
Storage temperature	-40 to 85 °C
Relative humidity (non cond.)	0 to 90%
Weight	approx. 80 g.

(*) inclusive of hysteresis, power supply variation and linearisation error.

(**) internally protected against polarity reversion.

DAT 2165: CONFIGURATION & CALIBRATION

- 1) Calculate the difference between the maximum and the minimum value of the input range (Span).
- 2) Refer to the " Input ranges table " and determine in the column " SPAN " the position where the calculated value is included, then referring to the position obtained, determine in the column "ZERO", the line in which the minimum value is included .
- Refer to the " Output ranges table " and determine in the column " Output signal " the position of the output value.
In the correspondent lines is shown as to set the DIP-switches .
- 3) Set the DIP-switches as indicated .
- 4) Connect on input a 3 wires Pt100 simulator programmed to supply the maximum and minimum values of the input range or a fixed resistor of the same values.
- 5) Set the simulator at the minimum temperature or to connect a fixed resistor correspondent to the minimum value .
- 6) By the ZERO potentiometer calibrate the output at the minimum value .
- 7) Set the simulator at the maximum temperature or to connect a fixed resistor correspondent to the maximum value .
- 8) By the SPAN potentiometer calibrate the output at the maximum value .
- 9) Repeat the operation from the step 5 to the step 8 until the output value will be correct (3 attempts typically required).

Configuration ex. : -30/200 °C out 0÷10 Vdc

Span => 200°C - (-30°C) = 230°C;

Input switches configuration (DSI) : Off, Off, Off, Off.

Output switches configuration (DSO) : Off, On, Off, On, Off.

INPUT RANGES TABLE

INPUT		DSI			
SPAN	ZERO	1	2	3	4
< 80°C (176°F)	- 50 to -25°C(-58 to -13°F)		●		
< 80°C (176°F)	- 25 to 12°C(-13 to 53°F)		●		●
< 80°C (176°F)	12 to 50°C(53 to 122 °F)		●	●	●
80 to 200°C(176 to 392°F)	- 50 to -25°C(-58 to -13°F)	●	●		
80 to 200°C(176 to 392°F)	- 25 to 12°C(-13 to 53°F)	●	●		●
80 to 200°C(176 to 392°F)	12 to 50°C(53 to 122 °F)	●	●	●	●
200 to 250°C(392 to 482°F)	- 50 to 50°C(-58 to 122°F)				
250 to 650°C(482 to 1202°F)	- 50 to 50°C(-58 to 122°F)	●			

OUTPUT RANGES TABLE

OUTPUT SIGNAL	DSO				
	1	2	3	4	5
0÷20 mA			●	●	●
4÷20 mA	●		●		●
0÷10 V		●		●	

● = DIP SWITCHES: " ON"

INSTALLATION INSTRUCTIONS

The device DAT 2165 is suitable for DIN rail mounting in vertical position.

It is necessary to install the device in a place without vibrations .
Moreover, it is recommended to use shielded cable to connect signals and to avoid routing conductors near power signal cables.

CONNECTIONS DAT 2165

INPUT CONNECTIONS

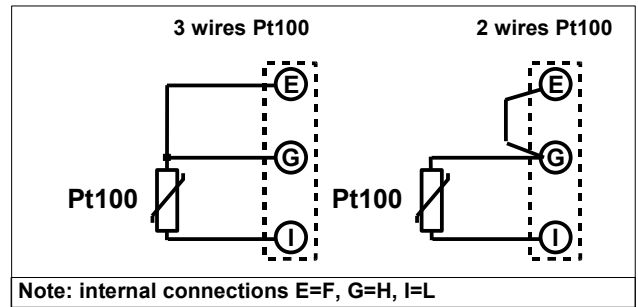

POWER SUPPLY CONNECTIONS

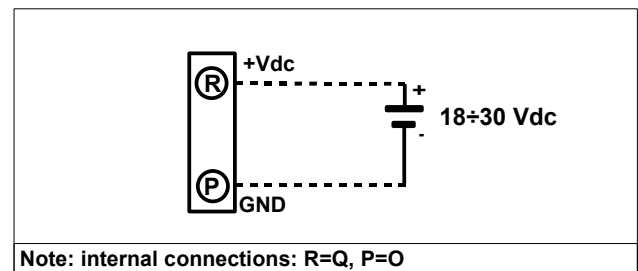

OUTPUT CONNECTIONS

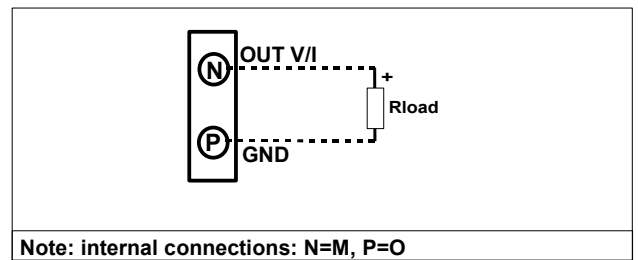

DIMENSIONS (mm) & SETTINGS

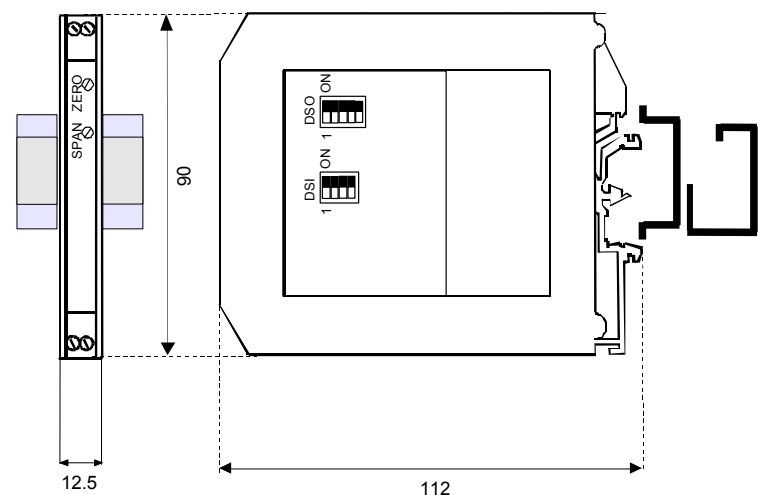

HOW TO ORDER

The DAT 2165 is supplied regulated as requested on the order.
In case of the configuration is not specified, the parameters must be set by the user.

ORDER CODE EXAMPLE: DAT 2165 0÷200 °C/°F 4÷20 mA

Input range Unit of measure Output range